

# 1. INTRODUCTION

**OM19X is a dot matrix impact printer that is available in 24 column, OM190, and 40 column, OM192, models. It is compact and reliable with a variety of features and options suitable for a wide array of applications including medical and industrial instruments, point of sale, test and measurement, security, time and attendance, etc.**

## 1.1 Features

- Easy paper loading and ribbon replacement
- Serial RS-232C or Centronics parallel
- Multiple international character set
- Auto power off features.
- User selectable options stored in non-volatile ram.
- Watch dog software shuts off power to the print head and carriage motor in a paper jam situation.
- Full 96 ASCII set (plus additional European/Chinese and scientific characters).
- 32kbyte buffer.
- Double width printing.
- Double height printing.
- Underlining.
- Built-in tab stops.
- Vertical tab.
- Form feed.
- Self-test.
- Inverted printing (data mode only).
- Graphics.
- Reset command.
- Software diagnostic mode.
- DH technology 1000 emulation.
- Epson ESC/POS emulation.
- Citizen 560 emulation.

## 2. SPECIFICATIONS

### 2-1. General specifications.

Model	OM190	OM192
Print method	Shuttle impact dot matrix (8 pins)	
No. of columns	24	40
Printing speed	2.5 lps	1.7 lps
No. of dots per line	144	240
Dot Size	0.33 (H) x 0.38 (W) mm	
Character size (mm)	1.7 (W) x 2.6 (H)	1.1 (W) x 2.6 (H)
Line Spacing	3 dot lines	
Font size	(5+1) x 7	
Interface	Type S: RS-232C serial Type P: Centronics parallel	
Emulation	Epson ESC/POS, Citizen 560, DH1000	
Data buffer	1 KB	
Ink ribbon	ERC-09 or ERC-22 (Purple or black)	
Paper	Width 57.5 ± 0.5 mm Diameter 60 mm (Max)	
No. of copies	Original + 1 copy	
Power supply	9 VDC ±10% 2.0 A	
Dimensions (mm)	178 (L) x 105 (W) x 82 (H)	
Reliability (MCBF)	1.5 million lines	0.9 million lines
Weight	400 g or 0.88 lbs	
Safety approvals	CE	
Operating condition	0 to 50 °C 10 to 80 % RH (Operating)	

### 2-2. Printer types and models:

Printer types and models are selected according to the following designation:

#### **OM19X - Y - Z**

X: Designates column capacity:

0	24 columns
2	40 columns

Y: Designates interface type

S	Serial interface
P	Parallel interface

Z: Designates input voltage for the external power adaptor

Blank	110VAC	WA	Without adaptor
220	220 –240 VAC	SMPS	90-240VAC

### 3. Setting up the printer

#### 3-1. Unpacking.

The items illustrated below are included with your printer. If any items are damaged or missing, please contact your dealer for assistance.

Printer, Paper Roll, Power Supply, Ribbon (installed), Manual, and Interface Cable.

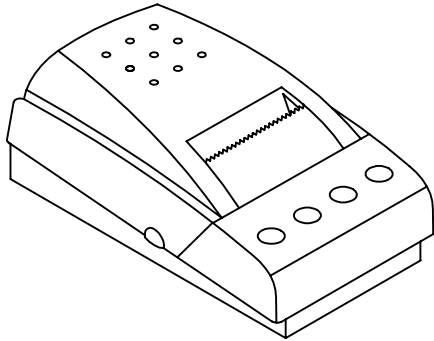

Printer

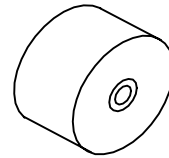

Paper roll

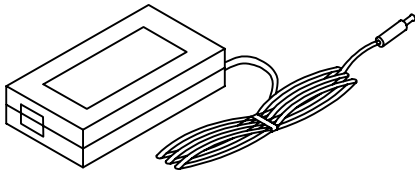

Power Adapter

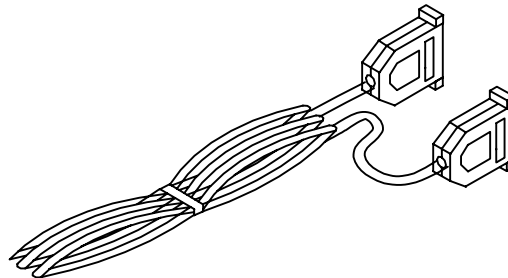

Interface Cable

#### 3-2. Selecting a Place

1. Protect your printer from excessive heat such as direct sunlight or heaters.
2. Avoid exposing the printer to excessive dust and humidity.
3. Place the printer on a firm, level surface free from intense vibration or shock.

### 3-3 Connecting the Power Adapter

This printer requires an external power supply. Be sure to use a power supply that matches the specifications.

1. Make sure the power switch is OFF.
2. Insert the output plug of the power adapter into the DC jack of the printer.
3. Plug the adapter or the power supply's cord into an outlet.
4. For best results use one of the following Omniprint adapters:

OMPS190-915-NA	(120VAC input)
OMPS190-915-EU	(220-240VAC input)
OMPS190-915-SMPS	(90-240VAC input)

Output: 9VDC 1.5A , 2.1mm x 5.5mm female plug , Center positive

### 3-4 Connecting the Interface Cable

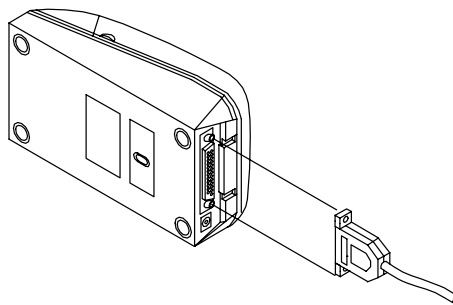

You need an appropriate serial interface or parallel interface cable to connect your computer to the printer.

#### 3-4-1 Serial Interface Cable: OM19□-S

1. Make sure that both the printer and computer are turned off.
2. The serial printer comes with a DB-25 female connector. Plug the DB-25 male end of the cable into the printer connector, as shown above.
3. Use a screw driver to fasten the cable screws to the two nut screws installed on the printer connector.
4. Connect the other end, DB9-F connector, to your computer.
5. Use Omniprint part number:

CBL-625F-25M	(DB-25 male on the host side)
CBL-69F-25M	(DB-9 male on the host side)

### 3-4-2 Parallel Interface Cable: OM19□-P

1. Make sure that both the printer and computer are turned off.
2. The parallel printer comes with a DB-25 male connector. Plug the DB-25 female end of the cable into the printer connector, as shown above.
3. Use a screw driver to fasten the cable screws to the two nut screws installed on the printer connector.
4. Connect the other end, DB25-M connector, to your computer.
5. Use Omniprint part number:

CBL-625M-25F-STR

### 3-5 Installing the Ribbon Cartridge

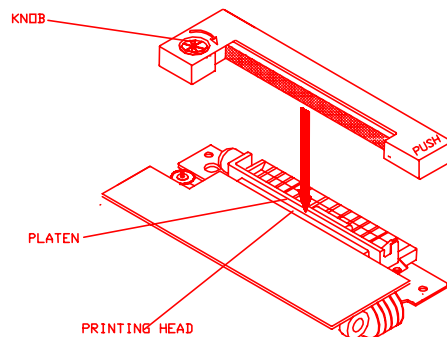

1. Turn the printer off before you open the printer cover.
2. Remove the old ribbon by pressing on the front right hand corner of the cassette where marked "PUSH".
3. Turn the ribbon cassette's knob in the direction of the arrow to take up any slack in the ribbon.
4. Insert the ribbon between the printer head and platen, as shown above, and push the cassette down until it snaps in place.
5. Turn the knob a few times again to take up any slack in the ribbon.
6. Use the following part number for ordering new ribbons:

Regular	ERC-09-□	( P for purple or B for black)
Long Life	ERC-22-□	( P for purple or B for black)

### 3-6 Loading Paper

Use a paper roll that meets the specifications. Do not use paper rolls that are glued to the core. Make sure data is not being transmitted to the printer while loading paper.

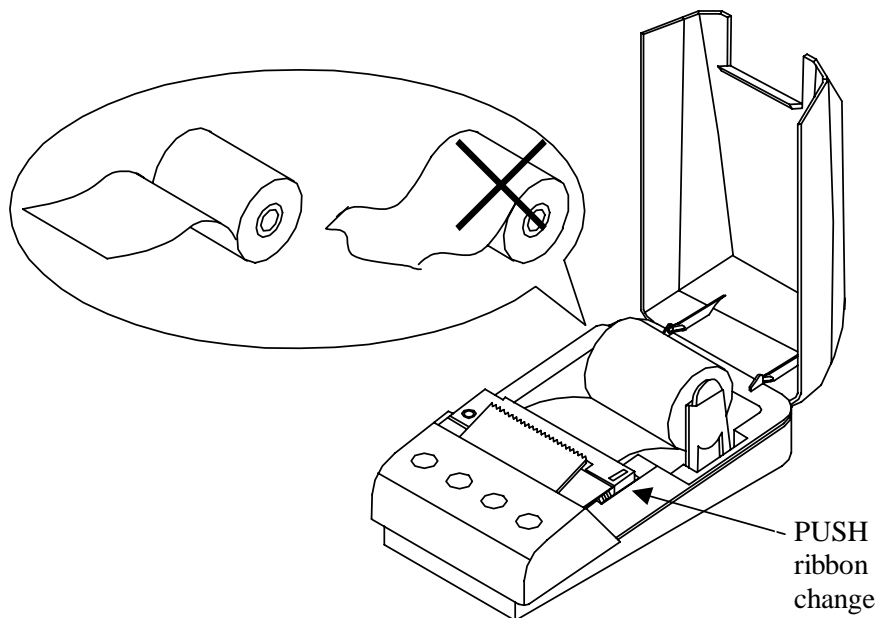

1. Cut the leading edge of the paper roll straight at a right angle, as shown above.
2. Remove the old paper roll, if any, and press the FEED button until any excess paper left in the mechanism is out. Do not pull the paper out of the printer mechanism paper inlet.
3. Mount the paper roll on the paper roll holder by gently bending the plastic tab, on the right, and insert the roll so that the holes in the core align with the axes of the paper roll holder. Make sure that the two holders are completely inside the core so that the paper roll can move freely without much friction, i.e. the core inside diameter is larger than the paper roll holder's outside diameter.
4. Hold the both edges of the paper and insert it straight into the paper slot.
5. Press the FEED button until approximately two inches of paper is fed through the mechanism.
6. Tear the excess paper against the serrated edge and close the cover.
7. Use the following Omniprint part number to reorder paper:

PP-225-135  
PP-225-90WC

1 ply paper roll  
2 ply paper roll

4. External Appearance.

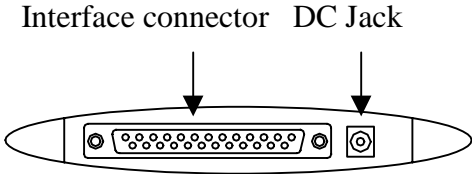
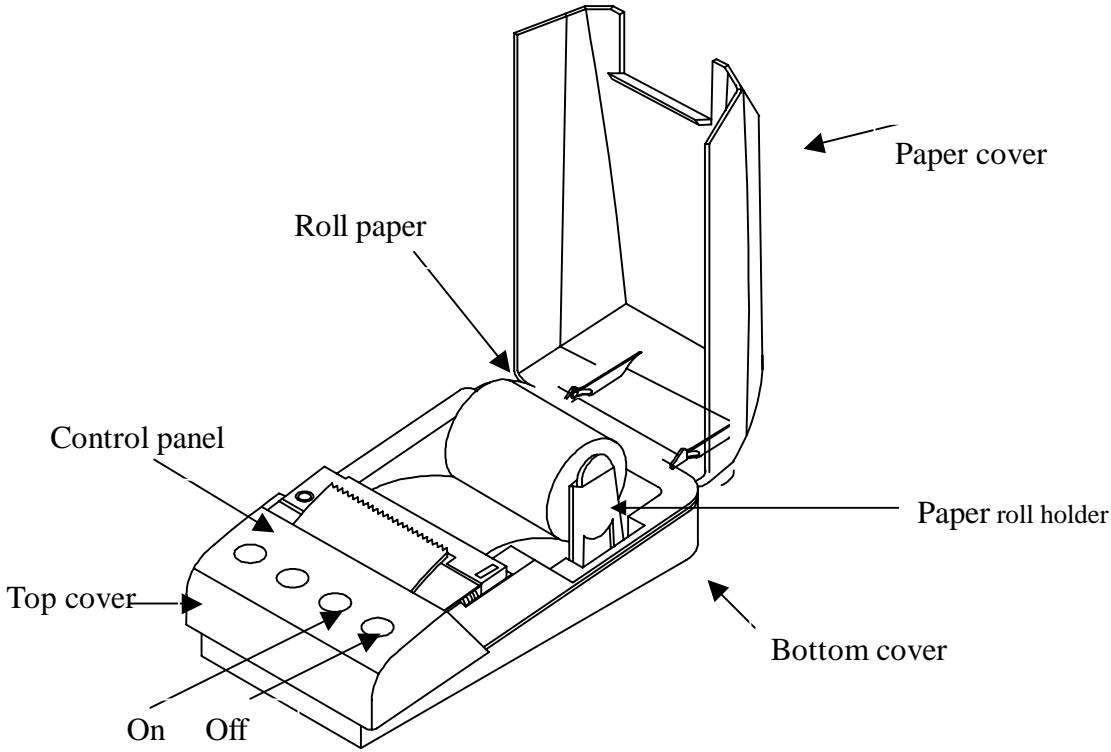

## 5. Control Panel

The control panel features four buttons and one LED to indicate printer status.

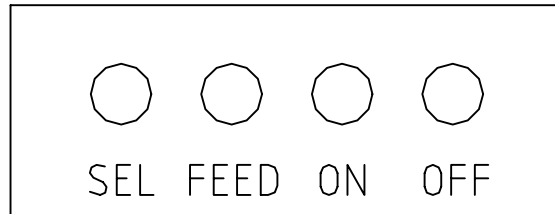

**ON BUTTON:** Press the ON button to power up the printer. A red LED inside the button will light up. The printer goes ON LINE ready to receive data from the host.

**OFF BUTTON:** Press the OFF button once to turn the power OFF.

**FEED BUTTON:** When the FEED button is pressed and then released within 0.5 sec., the paper feeds only one line. When the FEED button is held depressed for more than 0.5 sec., the paper feeds continuously.

**SEL BUTTON:** The SEL button is used to change the printer setting. (Please refer to the SET UP section for details)

**STATUS LED:** The LED is located inside the ON button and lights up when power to the printer is on. The LED flashes every second when the printer head jams and every 0.2 second in the case of mechanism malfunction.

## 6. Running the Self Test

Any time you want to check the performance of your printer you can run the self test described below. This shows whether your printer is working correctly.

1. While holding down the FEED button, turn the printer on.
2. The printer prints the model name, EPROM revision installed, and a few lines of the rotating character set.
3. The printer will automatically stop printing at the completion of the self test and enter the normal mode.

**NOTE:** THE PRINTER WILL GO OFF LINE AND WILL NOT COMMUNICATE WITH THE HOST WHILE IT IS IN SELF TEST MODE.

## 7. Default settings

Your printer is supplied with the following default setting.

DATA BITS	8
PARITY	NONE
BAUD RATE	9600
CHARACTER SET	U.S.
PRINT MODE	TEXT
AUTO-OFF	5MIN
EMULATION	STANDARD (ESC/POS)
DTR	NORMAL
INTERFACE	SERIAL

The factory default settings can be restored by simultaneously pressing the FEED and SEL buttons at power up. Releasing the FEED button before the SEL button will save the revised settings.

## 8. Set-up mode

### 8.1 Set-up By Control Panel Buttons

You can change the printer serial interface, character table, emulation, and print mode settings by following the procedure below:

1. By turning the power on while pressing the SEL button the printer will print the current configuration and get in SET-UP mode.
2. The power LED will flash every second to indicate the printer is in SET-UP mode.
3. By pressing the FEED button, in SET-UP mode, you can scroll through the printer parameters in the order shown in the table below.
4. Pressing the SEL button will cause the setting of a parameter to change in the sequence shown below.
5. Once the desired setting is selected, it can be saved by pressing the SEL button while pressing the FEED button.

**NOTE: IF NO BUTTONS ARE PRESSED FOR 15 SECONDS, THE SET-UP MODE IS AUTOMATICALLY TERMINATED WITHOUT CHANGING THE ORIGINAL PARAMETERS.**

PARAMETER (FEED Button)	STATUS (SEL Button)
NUMBER OF DATA BITS	8BIT DATA
	7BIT DATA
SERIAL PARITY	NO PARITY
	ODD PARITY
	EVEN PARITY
SERIAL BAUD RATE	2400 BAUD
	4800 BAUD
	9600 BAUD
	19200 BAUD
CHARACTER SET	U.S.A.
	FRANCE
	GERMANY
	U.K.
	DENMARK I
	SWEDEN
	ITALY
	SPAIN
	JAPAN
	NORWAY
	DENMARK II
	PRINT MODE
DATA(INVERTED PRINT)	
AUTO POWER OFF	5MIN
	1MIN
	DISABLE
EMULATION	STANDARD(DH1000)
	CITIZEN 560
	ESC/POS
DTR	NORMAL
	INVERTED

## 8.2 Set-up Through the Data Port

If the printer is turned on while pressing the SEL and FEED buttons, simultaneously, and only the SEL button is released, the printer will print : “nvr comms ready>”

At this point the printer is waiting to receive data in the following format : SET-UP mode + Carriage Return +n1+...n10  
(n1 to n10 are hex number) the SET-UP mode followed by a carriage return indicates that the printer should expect parameter data as shown in the table below.

Upon receiving information in the correct format, the printer will print : “data ok,nvr updated !”.

Note : If no data is received within 15 seconds or the FEED button is released before the procedure is complete, then the new setting will not be saved and the printer will print : “set error nvr unchanged “.

### 8.3 NVR COMMS

STRING " SET-UP MODE",ODH,N1,N2,N3,N4.....

		0	1	2	3	4	5	6	7	8	9	10
1	Data bit	7	8									
2	Parity	EVEN	ODD	NONE								
3	Baud rate	19200	9600	4800	2400							
4	Country	Denmark2	Norway	Japan	Spain	Italy	Swede n	Denmark l	U.K.	German y	Franc e	U.S.A.
5	Print mode	DATA	TEXT									
6	Auto off	Disable	1MIN	5MIN								
7	Emulation	ESC/PO S	560	Standar d								
8	Printing	Invert	Norma l									
9	Zero Status											
10	Reverse future											

### 8.4 Diagnostic Mode

To get in the diagnostic mode, perform self-test and keep pressing the FEED button until "diagnostic modes" is printed. Press the FEED button to end. The power-on indicator will flash every two seconds. Following is an example of the diagnostic mode:

Abc de fg .....normal print  
 Abcde nfogm .....diagnostic print out

In the above example the following sequence of characters was sent :  
 Character f, single width(o),character g, carriage return(m).

### 9. Accessories

- 1) Paper: 57.5mm+/-0.5mm(width), 60mm max(roll diameter), 85 microns (thickness)
  - PP-225-80 1-ply paper roll
  - PP-225-75WC 2-ply paper roll
  
- 2) Ribbon specification :
  - ERC-09 P (Purple) or B (Black) Standard cartridge
  - ERC-22 P (Purple) or B (Black) Long Life Cartridge
  
- 3) Interface Cable: 6 foot long, shielded cable with molded connectors.
  - CBL-625M-25F-STR Parallel cable
  - CBL-625F-25M Serial cable w/ DB-25F host side
  - CBL-69F-25M Serial cable w/ DB-9F host side
  
- 4)Power Supply: Output: 9VDC 1.5A, 2.1mm x 5.5mm female plug, center positive.
  - OMPS190-915-NA 120VAC input
  - OMPS190-915-EU 220-240VAC input
  - OMPS190-915-SMPS 90-240VAC input

## 10. Troubleshooting

### 1) IF THE POWER LED DOES NOT COME ON.

Make sure the power supply cables are securely plugged into the printer, the adapter, and the power outlet. Also, make sure that power is supplied to the power outlet. If the outlet is controlled by a switch or timer, use another outlet.

### 1)IF THE POWER LED IS ON BUT PAPER DOES NOT FEED.

This may be a head jam condition, first turn off the printer and make sure there is no paper stuck in the mechanism; however do not use force or a sharp object to remove the jammed paper.

### 2)IF THE PAPER IS NOT FEEDING PROPERLY.

If the printout looks squashed, make sure that the paper roll moves freely on the paper holder. If the paper is wrinkled on the edges, the roll may not loaded correctly. In that case remove the paper and reload.

### 4) IF THE PRINTER SOUNDS LIKE IT IS PRINTING BUT NOTHING IS PRINTED

Make sure a ribbon cartridge is installed properly that is not worn out. Please note that the ribbon needs to be in front of the paper.

If the printout is faint, turn the knob on the cartridge in the direction of the arrow. Also, see if the knob turns when the FEED button is pushed, if it does not, then the advance gear on the ribbon or the mechanism may be defective or worn out.

### 3)IF THE PRINTER DOES NOT COMMUNICATE WITH THE HOST.

Run the self test to check that the printer works properly. If the self test does not work contact your dealer or qualified service person. If the self test works properly, check the following:

- A. You are using the right interface cable.
- B. The connection on both ends of the cable between the printer and the host.
- C. The data transmission setting may be different between the printer and the host. Use the SET-UP instructions to change the settings, if necessary.

### 4)IF A LINE OF DOTS IS MISSING IN THE PRINTOUT.

The print head may be damaged. Contact your dealer or qualified service person.

## 11. Interface connections

The OM19□ printer is available in RS-232C serial and Centronics compatible parallel versions. The interface type is printed on the self-test printout. The connector for the serial interface is a DB25 female and male for parallel.

### 11-1. SERIAL INTERFACE

#### 11-1-1 Serial Interface Specifications

Data Transmission Method: Asynchronous serial interface  
 Baud Rate: User selectable from 2400, 4800, 9600, 19.2K  
 Word Length: Data bit 7 or 8 bit  
 Parity Odd, Even, None  
 Stop bit 1 bit  
 Signal Polarity: MARK: Logic "1" (-10V)  
 SPACE: Logic "0" (+10V)  
 Input Control (DTR signal) : Mark: Data transmission not possible  
 Space: Data transmission possible

#### 11-1-2 Connector Pin Assignment

FUNCTION	PIN NUMBER	INPUT-OUTPUT
RXD	3	IN
TXD	2	OUT
CTS	5	IN
RTS	4	OUT
DSR	6	IN
GND	7,9,14	
*POWER	12,13,16	IN
NC	5,6,8,10,11,15,17-19,21-25	
F-GND	1	
DTR	20	OUT

\* Please note that some models can be set at the factory to receive power through the serial port.

#### 11-1-3 Serial Interface Timing Diagram

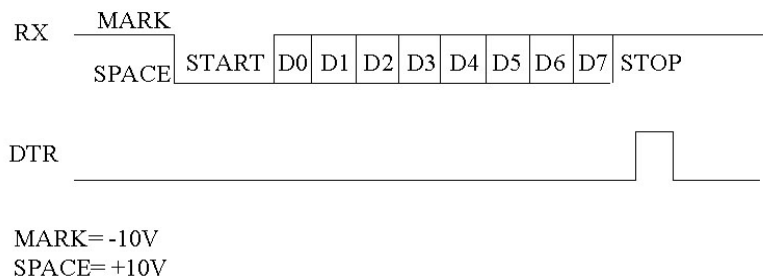

## 11-2. PARALLEL INTERFACE

### 11-2-1 Parallel Interface Specifications

Data Transmission Method: 8 bit parallel, DATA0 – DATA7  
Synchronization: Via external STROBE pulses  
Handshaking: ACK and BUSY signals  
Data Transfer Rate: 1000 to 6000 characters per second  
Logic Level: Compatible with TTL level

### 11-2-2 Parallel Connector Pin Assignment

PIN	FUNCTION	PIN	FUNCTION
1	STROBE	14	N.C.
2	DATA 0	15	N.C.
3	DATA 1	16	N.C.
4	DATA 2	17	N.C.
5	DATA 3	18	N.C.
6	DATA 4	19	+9V
7	DATA 5	20	+9V
8	DATA 6	21	GND
9	DATA 7	22	GND
10	ACK	23	GND
11	BUSY	24	GND
12	N.C.	25	GND
13	N.C.		

Printer is capable of receiving data from the host while the BUSY signal is in the LOW state and communication will be interrupted when the signal is HIGH>

## 12. COMMAND CODES

### 12.1 COMMAND SUMMARY FOR DH1000 EMULATION

FUNCTION	KEYSTROKE	HEX	DECIMAL
HORIZONTAL TAB	CTRL I	09H	9
LINE FEED	CTRL J	0AH	10
FORM FEED	CTRL K	0BH	11
VERTICAL TAB	CTRL L,n	0CH,n	12,n
CARRIAGE RETURN	CTRL M	0DH	13
DOUBLE WIDTH	CTRL N	0EH	14
SINGLE WIDTH	CTRL O	0FH	15
RESET	CTRL Q	11H	17
UNDERLINE	CTRL U	15H	21
UNDERLINE RELEASE	CTRL X	18H	24
REVERSE PRINT	CTRL Y	19H	25
DOUBLE HEIGHT	CTRL Z	1AH	26
GRAPHICS	CTRL [,n	1BH, n	27,n

### 12.2 COMMAND SUMMARY FOR EPSON ESC/POS EMULATION

FUNCTION	KEYSTROKE	HEX	DECIMAL
HORIZONTAL TAB	CTRL I	09H	9
LINE FEED	CTRL J	0AH	10
FORM FEED	CTRL L	0CH	12
CARRIAGE RETURN	CTRL M	0DH	13
SET PRINT MODE	ESC ! n	1BH,21H,n	27,33,n
INITIALIZE PRINT	ESC @	1BH,40H	27,64
CHARACTER SET	ESC R n	1BH,52H,n	27,82,n
PRINT & FEED	ESC d n	1BH,64H,n	27,100,n
STATUS REQUEST	ESC v	1BH,76H	27,118
INVERTED PRINTING	ESC { n	1BH,7BH,n	27,123,n
SET FORM LENGTH	ESC C n	1BH,43H,n	27,67,n

### 12.3 COMMAND SUMMARY FOR CITIZEN 560 EMULATION

FUNCTION	KEYSTROKE	HEX	DECIMAL
LINE FEED	CTRL J	0AH	10
FORM FEED	CTRL L	0CH	12
CARRIAGE RETURN	CTRL M	0DH	13
REVERSE PRINT	CTRL T	14H	20
CLEAR BUFFER	CTRL X	18H	24
GRAPHIC PRINT	ESC K	1BH,4BH	COMMANDS ACKNOWLEDGED BUT NOT EXECUYED
PAGE LENGTH/FORMAT	ESC C	1BH,43H	
PAGING IS OFF	ESC 0	1BH,4FH	
2.75MM SPACING	ESC 1	1BH,31H	
5.5MM SPACING	ESC 2	1BH,32H	
DOUBLE WIDTH		1EH	30
SINGLE WIDTH		1FH	31

## 11.2 COMMAND DESCRIPTIONS

### 11.2.1 COMMAND DESCRIPTION FOR DH1000 EMULATION

**TAB(09H)** : Moves the print position to the next horizontal tab position. The default tab positions are at every 8 character intervals. This command will be ignored unless the next horizontal tab position is set.

**LINE FEED(0AH)** : Prints the data in the print buffer and feeds one line based on the current line spacing . IF LF+CR IS SENT, CR WILL BE IGNORED TO AVOID DOUBLE FEEDING.

**FORM FEED(0BH)** : The printer fast feeds to the top of form set by software. Any character in the buffer will be printed and the buffer pointer will be reset.

**VERTICAL TAB(0CH,N)** : Printer feeds the paper by N lines. N is a single byte hex number in the 0<n<20h range. Note that a vertical tab will print the contents of the line buffer before being executed.

**CR(0DH)** : This command prints the data in the print buffer and feeds one line. If a LF is sent immediately after CR, it will be ignored to avoid double printing. When the line buffer is full, ie upon receiving the 24<sup>th</sup> and 40<sup>th</sup> characters in the case of OM190 and OM192, respectively, the printer will automatically print the data in the buffer. If CR or LF is sent, they will be ignored in this situation.

**DOUBLE WIDTH(0EH)** : Upon receiving this command the printer will go in the double wide mode and remains in this mode until terminated by the single wide command or completion of the current line. If the last character of a line is double wide but there is room only for a single wide character, it will be printed in single width.

**SINGLE WIDTH(0FH)** : Printer reverts back to single width printing. Single and double wide characters can be combined anywhere on a line.

**RESET(11H)** : This commands causes the printer to be set to power up default conditions.  
NOTE THAT THIS WILL NOT CLEAR THE BUFFER OF ANY DATA PREVIOUSLY SENT.

**UNDERLINE(15H)** : Characters sent after this command will be underlined. Tabs are not underlined. Underlining is terminated by the underline release command or upon completion of the current line.

**UNDERLINE RELEASE(18H)** : Terminates the underline mode.

**REVERSE PRINT(1AH)** : This command causes the printer to print white on black. You can toggle between reverse and normal anywhere on a line but the reverse print mode will automatically be terminated at the end of a line.

**DOUBLE HEIGHT(1AH)** : Upon receiving this command the printer will go in the double high mode and remains in this mode until terminated by the single wide command or completion of the current line.

NOTE THAT DOUBLE HEIGHT AND SINGLE HEIGHT CHARACTERS CANNOT BE COMBINED ON THE SAME LINE.

**GRAPHICS(1BH,N)** : This command causes the printer to go in the bit image printing mode. The number of graphic bytes sent will depend on the type of mechanism. For each graphic byte sent to the printer, 6 out of 8 bits are used to form the graphic string (LSB is the right most dot). N is the number of times the string will be repeated for a repetitive pattern, 0<N<255 lines. The print buffer will be printed first if not empty.

EXAMPLE : TO REPEAT A STRING OF DATA BYTES,D1----D24 OVER TWO ROWS FOR OM190:  
SEND : 1BH,D1-----D24. FOR A NON-REPEATED STRING SEND :1BH,01H,D1-----D24.

## 11.2.2 EPSON ESC/POS COMMAND DESCRIPTION

**TAB(09H)** : : Moves the print position to the next horizontal tab position. The default tab positions are at every 8 character intervals. This command will be ignored unless the next horizontal tab position is set.

**LINE FEED(0AH)** : Prints the data in the print buffer and feeds one line based on the current line spacing . IF LF+CR IS SENT, CR WILL BE IGNORED TO AVOID DOUBLE FEEDING.

**FORM FEED(0CH)** : Prints the current line and feeds the number of lines programmed by using the ESC C command.

**CR(0DH)** : This command prints the data in the print buffer and feeds one line. If a LF is sent immediately after CR, it will be ignored to avoid double printing.

**ESC ! n(1BH,21H,n)** : Sets the print mode according to the following table. n is a single byte in which each bit sets the printing function. Note that underline cannot be used with a horizontal tab and any combination of double height and width can be used. Default is n=0.

Bit	Off/On	Hex	Decimal	Function
0,1,2	---	---	---	Undefined
3	Off	00	0	Emphasized mode off
	On	08	8	Emphasized mode on
4	Off	00	0	Double-height off
	On	10	16	Double-height on
5	Off	00	0	Double-width off
	On	20	32	Double-width on
6	---	---	---	Undefined
7	Off	00	0	Underline mode off
	On	80	128	Underline mode on

**ESC @(1BH,40H)** : Initialize the printer. Clears the print buffer and resets the printer to default values.

**ESC R n(1BH,52H,n)** : Selects the international character set form the following table

n	Character set
0	U.S.A.
1	France
2	Germany
3	U.K.
4	Denmark I
5	Sweden
6	Italy
7	Spain
8	Japan
9	Norway
10	Denmark II

**ESC d n(1BH,64H,n)** : Prints the data in the print buffer and feed n lines.

**ESC v(1BH,76H)** : The current printer status is transmitted to the host upon receipt of this command.

The printer transmits one byte of data to the host indicating the status of the paper out detector. It takes the form of a single byte which is fixed at 0 (to indicate paper in) for printer. The Byte is sent regardless of the CTS handshaking signal.

**ESC { n(1BH,7BH,n)** : Inverted print command. If n=1 then printing will be inverted and text will be printed from right to left. For normal printing n=0. The default mode is set by the programmed parameters in the printer.

**ESC C n(1BH,43H,n)** : Set form length. When used in conjunction with the form feed command(0ch), the printer will feed n lines. NOTE THAT IF n=0, THEN THERE WILL BE NO LINE FEED.

### 11.2.3 COMMAND DESCRIPTION FOR CBM560 EMULATION

**LINE FEED (0AH)** : Prints the data in the print buffer and feeds one line.

**FORM FEED(0CH)** : Form feeds after printing. This is fixed at three lines.

**CR(0DH)** : Feeds a new line after printing.

**REVERSE PRINT(14H)** : This command causes the printer to print white on black. You can toggle between reverse and normal anywhere on a line but the reverse print mode will automatically be terminated at the end of a line.

**CLEAR BUFFER(18H)** : All the data in the print buffer, received prior to this command, will be cleared; however, this code is treated as data in the graphics mode.

**DOUBLE WIDTH(1EH)** : Upon receiving this command the printer will go in the double wide mode and remains in this mode until terminated by the single wide or LF command or completion of the current line. If the last character of a line is double wide but there is room only for a single wide character, it will be printed in single width.

**SINGLE WIDTH(1FH)** : Printer reverts back to single width printing. Single and double wide characters can be combined anywhere on a line.

## APPENDIX 1. INTERNATIONAL CHARACTERS SET

	23h	24h	40h	5Bh	5Ch	5Dh	5Eh	60h	7Bh	7Ch	7Dh	7Eh
U.S.A.	#	\$	@	[	\	]	^	`	{		}	~
FRANCE	#	\$	à	°	ç	§	^	`	é	ù	è	“
GERMANY	#	\$	§	Ä	Ö	Ü	^	`	ä	ö	ü	ß
U.K.	£	\$	@	[	\	]	^	`	{		}	~
DENMARK I	#	\$	@	Æ	Ø	Å	^	`	æ	ø	å	~
SWEDEN	#	×	É	Ä	Ö	Å	Ü	é	ä	ö	å	ü
ITALY	#	\$	@	°	\	é	^	ù	à	ò	è	ì
SPAIN	Pt	\$	@	í	Ñ	¿	^	`	ñ	n	}	~
JAPAN	#	\$	@	[	¥	]	^	`	{		}	~
NORWAY	#	×	É	Æ	Ø	Å	Ü	é	æ	ø	å	ü
DENMARK II	#	\$	É	Æ	Ø	Å	Ü	é	æ	ø	å	ü

## APPENDIX 2. PRINTABLE CHARACTER SET

	2	3	4	5	6	7	8	9	A	B	C	D	E	F
0	SP	0	@	P	'	p	Ç	É	á	█	⊥	⊥	α	=
1	!	1	A	Q	a	q	ü	æ	í	█	⊥	⊥	β	±
2	"	2	B	R	b	r	é	Æ	ó	█	⊥	⊥	Γ	≥
3	£	3	C	S	c	s	â	ô	ú		⊥	⊥	π	≤
4	\$	4	D	T	d	t	ä	ö	ñ	†	-	⊥	Σ	∫
5	%	5	E	U	e	u	à	ò	Ñ	†	†	⊥	σ	∫
6	&	6	F	V	f	v	ã	û	ª	‡	‡	⊥	μ	÷
7	'	7	G	W	g	w	ç	ù	º	⊥	‡	‡	τ	≈
8	(	8	H	X	h	x	ê	ÿ	¿	‡	⊥	‡	Φ	°
9	)	9	I	Y	i	y	ë	Ö	⊥	‡	⊥	⊥	θ	·
A	*	:	J	Z	j	z	è	Ü	⊥	‡	⊥	⊥	Ω	·
B	+	;	K	[	k	{	ï	ϕ	½	⊥	⊥	█	δ	√
C	,	<	L	\	l		î	£	¼	⊥	‡	█	∞	<sup>n</sup>
D	-	=	M	]	m	}	ì	¥	ì	⊥	=	█	∅	<sup>2</sup>
E	.	>	N	^	n	~	Ä	Pt	«	⊥	‡	█	ç	■
F	/	?	O	_	o	SP	Å	f	»	⊥	⊥	█	n	

**APPENDIX 3. EXTERNAL DIMENSIONS**

